

## De schakeling

In deze les gaan we een joystick gebruiken om 4 leds aan te sturen.

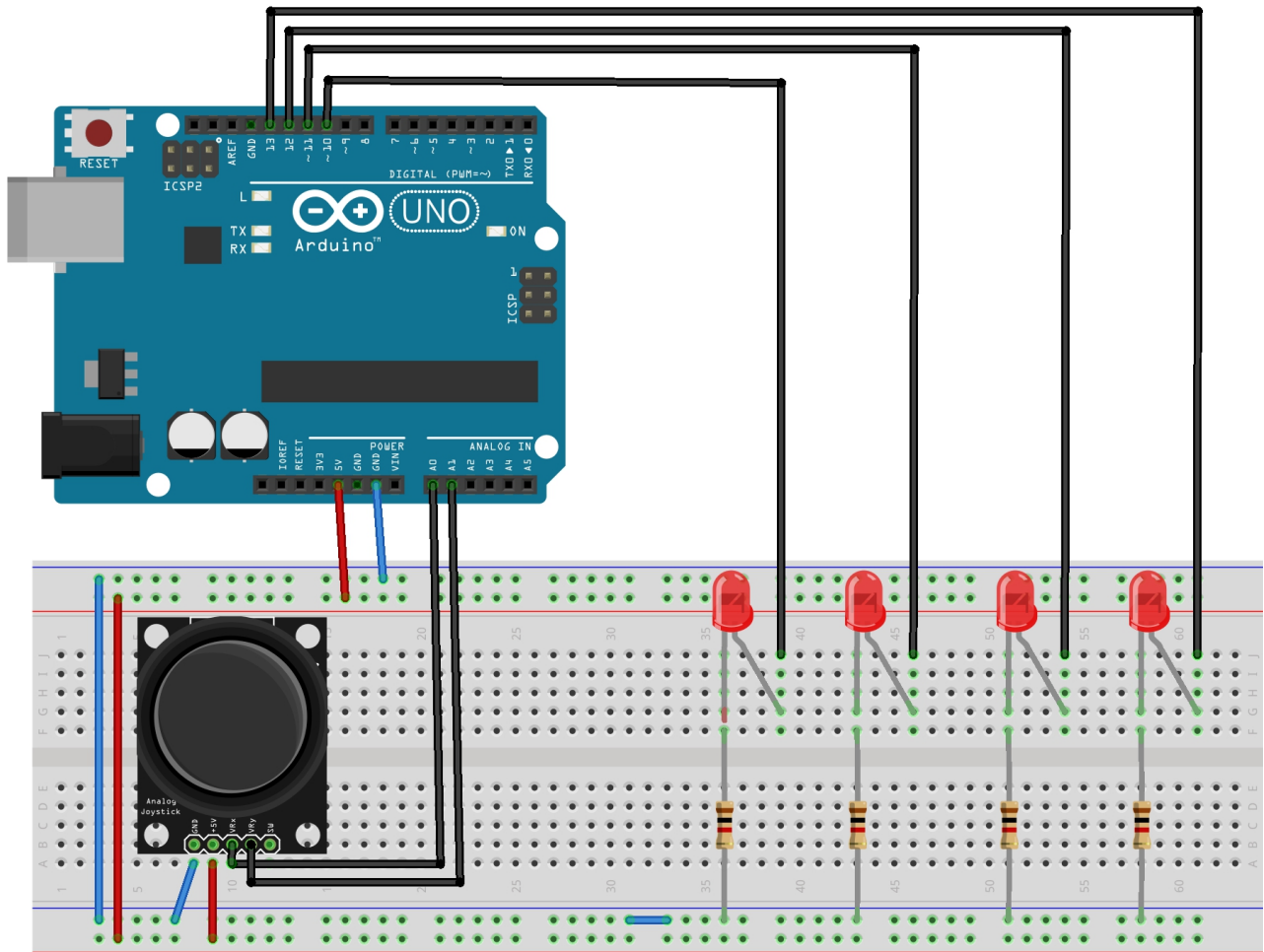

fritzing

## De code

```
int UD = 0;
int LR = 0;
/* Arduino Micro output pins*/
int DWN = 13;
int UP = 12;
int LEFT = 11;
int RT = 10;
/*Arduino Micro Input Pins */
int IUP=A0;
int ILR=A1;
int MID = 10;
int LRMID = 0;
int UPMID = 0;
void setup(){
    pinMode(DWN, OUTPUT);
    pinMode(UP, OUTPUT);
    pinMode(LEFT, OUTPUT);
    pinMode(RT, OUTPUT);
    digitalWrite(DWN, HIGH);
    digitalWrite(UP, HIGH);
    digitalWrite(LEFT, HIGH);
    digitalWrite(RT, HIGH);
    LRMID = analogRead(ILR);
    UPMID = analogRead(IUP);
}
void loop(){
    UD = analogRead(IUP);
    LR = analogRead(ILR);
    if(UD < UPMID - MID){
        digitalWrite(DWN, HIGH);
    }else{
        digitalWrite(DWN, LOW);
    }
    if(UD > UPMID + MID){
        digitalWrite(UP, HIGH);
    }else{
        digitalWrite(UP, LOW);
    }
    if(LR < LRMID - MID){
        digitalWrite(LEFT, HIGH);
    }else{
        digitalWrite(LEFT, LOW);
    }
    if(LR > LRMID + MID){
        digitalWrite(RT, HIGH);
    }else{
        digitalWrite(RT, LOW);
    }
    delay(400);
}
```